



Hegewald & Peschke

Meß- und Prüftechnik GmbH

Product information

Rotational impact tester



Hegewald & Peschke Meß- und Prüftechnik GmbH
Am Gründchen 1, 01683 Nossen, Germany
Telephone: +49 35242 445-0, Telefax: +49 35242 445-111
E-Mail: info@Hegewald-Peschke.de
<http://www.Hegewald-Peschke.de>

Application:

- Highly dynamic tensile tests with a long linear test path
- Testing of fibre composites and technical textiles (optionally extendable with other rotation masses for other materials)
- Testing of bonding points (e.g. seams, glued joints)
- Realisation of strain rates up to 350 s^{-1}

Material characteristics at such high strain rates are used for crash simulations, e.g. in lightweight construction or in the automotive industry. They simulate the material behaviour at 50 km/h (14 m/s).

Functionality:

In this rotational impact tester, a 300 kg rotating flywheel mass is decisive for the resulting speed and energy storage. This energy is transferred to a linear slide with integrated specimen holder for testing. The actual tensile test then only takes a few milliseconds. During this time, the physical measured variables force, displacement and time are recorded.

The machine is completely operated via a touch panel and the recorded measurement data is stored in a buffer memory. The values are then automatically imported into LabMaster and are available for individualised evaluation. LabMaster works on the basis of an SQL database and is also used for traceable measurement data backup.

Results:

- Strain rates
- Force-displacement diagrams
- Modulus of elasticity, tensile strength and elongation at break at defined strain rates
- The area below the force-displacement diagram represents the work performed and corresponds to the energy dissipated

The strain rate indicates the rate of strain within a defined test piece length.

$$\text{Strain rate } \dot{\epsilon} = \frac{v}{L}$$

v : speed, L : specimen length

A dynamic test and thus a crash-relevant strain rate is obtained by a high testing speed with a comparatively short specimen.

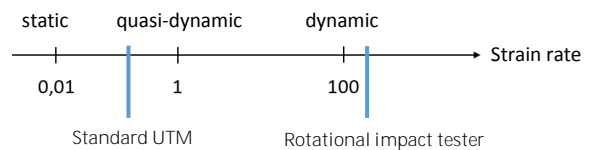

The system works with a measuring frequency of 400 kHz, which guarantees fast and accurate data recording.

Specimen / clamping possibilities:

Fibre-plastic composites (FRP) and technical textiles can be clamped in the rotational impact tester. The clamping is effected via a form-fitting connection. In the case of textile specimens, the head area is reinforced by a kind of glue-on. Due to the different geometries in the head area of the specimens, an inlay is used. Therefore a standardised clamping device can be used.

Specimen characteristics technical textiles:

- Parallel length: 40 mm
- Specimen width: 35 mm
- Specimen thickness: max. 4 mm

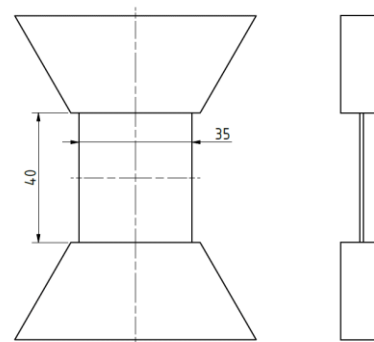



Specimen characteristics fibre composites (FRP):

- Parallel length: 40 mm
- Specimen thickness: max. 4 mm
- Specimen geometry: flat specimen in accordance to DIN 50125 shape D

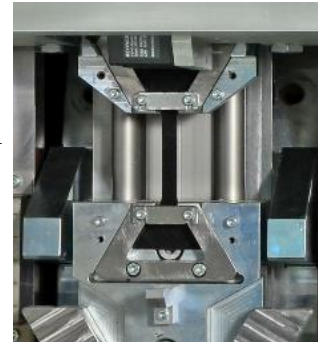
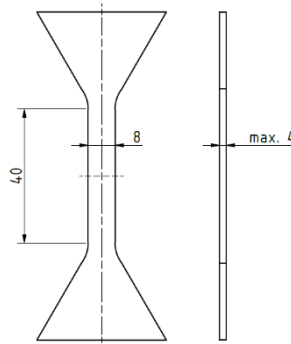

Technical data:

Force measurement		Tensile load	Preload force
		up to 80 kN	5 kN
Measuring range		100 – 80,000 N	1 – 5,000 N
Resolution		2.5 N	1 N
Measuring frequency		400 kHz	
Displacement measurement			
Measuring range		+/- 3,6 mm (at 2,55 µs scanning cycle)	
Resolution		0.1 µm	
Test speeds/ strain rates			
Testing speed		1 - 14 m/s (4 - 50 km/h)	
Rotating mass		300 kg	
Rotation energy		16.300 J (at 14 m/s)	
Strain rate		up to 350 s ⁻¹	
Connection conditions			
Electrical		400 V 3 P/N/PE 50 Hz 7.5 kVA, via 32A CEE plug on the machine, Leakage current ca. 40 mA, back-up fuse >= 3B16 A If available, only all-current sensitive RCDs (RCDs) may be used Indoors 5- 40°C, 20- 80 % humidity, non-condensing	
Pneumatic		compressed air 6 ... 10 bar; compressed air quality according to ISO/DIS 8573-1 (residual oil content better than class 2; residual dust content better than class 3; residual water content better than class 4)	
Dimensions (HxWxD) [mm]		1700 x 1130 x 1530	
Weight		approx. 1,700 kg	
Necessary accessories		PC, testing software LabMaster	

Operation, data transmission, operation of the rotational impact tester:

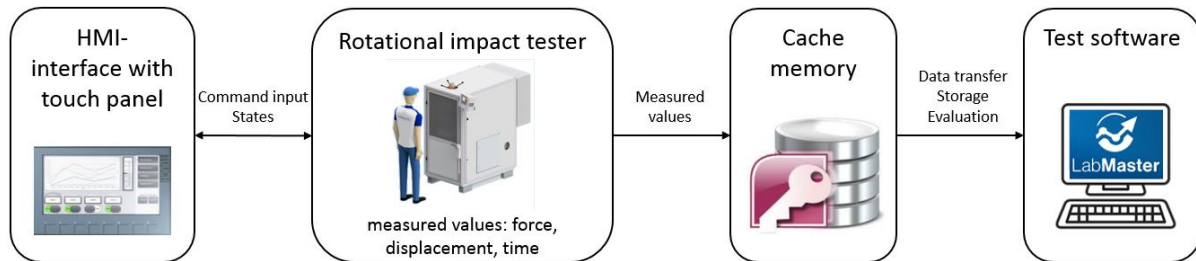

Comparison of testing machines with similar applications:

In this test series, the rotational impact tester impresses with its high testing speed and high impact energy, at a comparatively small machine size.

	Rotational impact tester	Pendulum impact tester	Drop tester	High-speed testing machine
Impact energy	up to 16,000 J Test energy is defined by flywheel mass and test speed	up to 750 J Test energy is defined by pendulum mass and deflection angle	up to 100,000 J Test energy is defined by drop weight and drop height	
Testing speed	up to 14 m/s	up to 5 m/s	up to 10 m/s (for a fall height of 5 m)	up to 20 m/s
Test forces	up to 80 kN			up to 100 kN
Advantages	+ Specific setting of relatively high test speeds + small space requirement + relatively high test forces + high energies despite small flywheel mass (300 kg)	+ standardised procedure + simple operation	+ standardised component testing	+ large specimen dimensions + relatively high test loads
Disadvantages	- no standardised procedure	- limited by deflection angle - low impact energy	- high space requirement - cost-intensive - extremely complex evaluation	- cost-intensive - high-maintenance